



DESIGO™ PX

Operator unit

Version 2.1

PXM20

Networkable operator unit for viewing and operating one or several DESIGO PX automation stations.

- High-grade display with adjustable contrast
- Simple key operation with direct access to the required plant information
- Generic operation and display of plant functions (alarm handling, time schedulers, calendars, setpoint adjustments, display of current values, etc.)
- Integrated acoustic and/or visual collective alarm
- Graphic online-trend function
- Support of integrated access protection in the overall DESIGO system
- Ability to add or delete new users
- Automatic logout
- Heating curve graphics
- System date and time setting
- Wiring test for IOs
- Context-sensitive help function
- Installation in modular automation station PXC..-U or remote

Application

The PXM20 operator unit ensures the convenient display and operation of DESIGO PX automation stations via BACnet network communication. The graphics-based display with clear text and direct access via the keyboard ensure a most user-friendly operation.

Functions

All values visible in the system can be displayed in accordance with the defined operator profile. Typical displays:

- Display of current values
- Setpoint and parameter settings
- Maintenance and error messages
- Alarm lists and single alarm messages with acknowledgement option and/or reset
- Time schedulers (7-day schedules and exception programs)
- Plant switching
- Login and password inputs

An integrated collective alarm message system with acoustic and visual indication is provided.

Operating concept

As the PXM20 operator unit is designed for end-user operation the operating concept concentrates on the simplest and clearest possible display following intuitive operating principles rather than displaying as many values as possible.

- Any text is displayed as clear text in the chosen language.
- To ensure a clear orientation for any operator the two top display lines (header lines) always show which building services system or which function is currently in operation.
- The basic concept of the operation ensures that it is always possible to select direct, with the click of a button on the keyboard, the plant information shown on the relevant line (*direct access keys*).
- Any settings or modifications (for example in graphics) can be followed direct on the display (e.g. graphics display for scheduler).
- The basic concept also ensures that all information and help functions can be called up any time (info key).

Indicators and operator controls

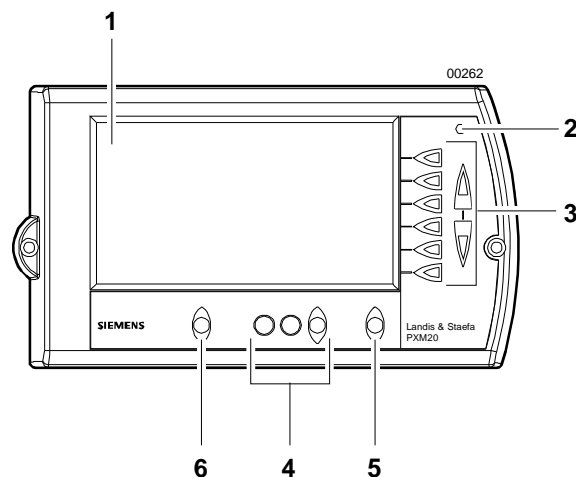

- 1 Display
- 2 Alarm LED: The alarm LED lights up or flashes if an alarm is present in the system.

- 3 Navigation keys (*direct access* keys and *PageUp/PageDown* keys):
 The *direct access* keys allow direct access to the relevant line. Possible functions:
 - Select value and start the value adjustment
 - Confirm new value
 - Start function
 - Open object
 The *PageUp* and *PageDown* keys are provided for page scrolling if a page contains more values than can be shown on the display at the same time.
- 4 Edit keys: These keys allow the selected values to be modified (<+> and <->) and confirmed (<.J>).
- 5 *Undo* and *GoUp* key: When editing a value the editing process can be cancelled by using the *Undo* key (previous value will be displayed again). Otherwise the *GoUp* key selects the hierarchically higher object.
 This key is placed between the two blocks containing the navigation and editing keys because, according to its function, it belongs to both.
- 6 Info key: This key selects the information mode for the next keyboard click.

Generic operation and display

Due to the application program each menu tree is different. Navigation through the menu tree is based on the so-called *ClickDown* procedure using the navigation keys.

Alarms and events

If the PXM20 receives an alarm or an event appears on the display a pop-up window appears with the relevant information.

Visual and acoustic alarm

When an alarm is present the alarm LED flashes and changes to steady light when all alarms have been acknowledged. The acoustic alarm is provided as an option and can be activated optionally when an alarm is triggered.

AlarmViewer

Alarms are written into the AlarmViewer with a symbol, a description and a time/date stamp in chronological order. An acknowledgement mask to acknowledge alarms can be called up in the AlarmViewer. After acknowledgement the alarm entry disappears from the AlarmViewer; however, it will continue to be saved in the history list. Further details can be viewed in the alarm history (e.g. out of service, overridden, deadband, present value, etc.)
 The PXM20 history can contain max. 60 entries; the older ones are deleted.

Scheduler

The Scheduler allows the user a time-dependent switch on/off and the programming of time-dependent setpoint adjustments.
 The Scheduler consists of a 7-day schedule and an exception program.

7-day schedule

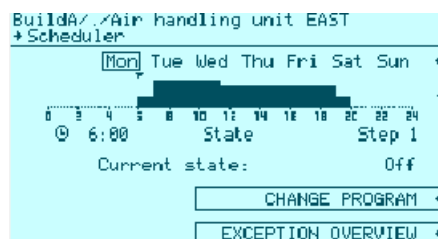

With the help of the navigation and editing keys it is very simple to create, modify, delete or copy a 7-day schedule in this mask. For each day an individual "road map" is programmed.

Exception programs

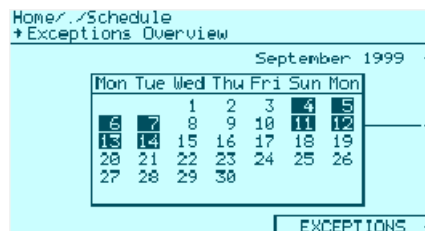

If the field *EXCEPTION OVERVIEW* is clicked in the *7-day schedule* (see above) the current monthly overview appears and shows as inverted all the days which are affected by an exception. All other months can be called up as overview by using the top *direct access* key.

In the exception program, too, the exceptions are created, modified or deleted by using the navigation and editing keys. It is possible to define exception days (e.g. a bank holiday) as well as exception periods (e.g. holiday periods). Click the *EXCEPTIONS* field to display a list of all programmed exceptions.

Online trend

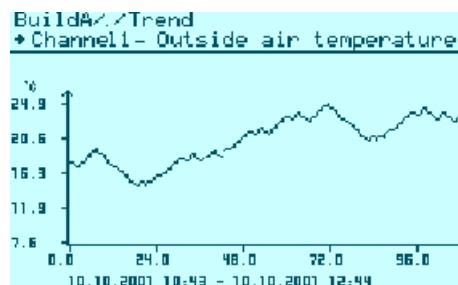

The PXM20 operator unit provides the user with five channels for trend logging, enabling 5 data points to be logged.

There are three separate ways of viewing the trend data:

- 1 Graphical view: In this view all the values of a trend datapoint stored in PXM20 will be displayed graphically
- 2 Online graphical view : In the online view the values will be displayed in a graphical and dynamic manner, i.e. in real time.
- 3 List: In place of a graphic view, the values can be displayed in list form

Info concept

Press info key to switch to info mode. In this info mode two different kind of information can be called up:

- Pressing the info key a second time displays general information for the currently displayed object (e.g. complete path, clear text of object).
- Pressing a *direct access* key in info mode displays information for the object or value on the selected line.

Exit the info mode by pressing any key.

Access protection

- Login by entering password with string editor
- Display and operation in accordance with user privileges
- Definition of user privileges during engineering of DESIGO PX configurations
- Login always referenced to a site
- Wiring test possible without login
- Alarms
 - Alarm display depends on user privilege
 - Alarm handling in accordance with user privileges
- Logout

Auto logout and sleep mode

If no operator activities are carried out within a set period the device switches off automatically and the display is turned off.

Pressing any key activates the device automatically again and the background lighting of the display is switched on.

Language versions

When the operator unit is delivered the language is set to English. The language setting can be changed internally to one of the following languages: Dutch, French, German, Italian and Swedish.

Ordering

1 PXM20 operator unit

Compatibility

Device	Type	Data sheet
Compact automation stations	PXC...	9211
Modular automation stations	PXC...-U	9221

Design

The PXM20 operator unit is contained in a robust plastic housing, ideally suited for its many different mounting methods.

All indicators and controls are mounted on the front cover of the unit (see page 2).

The connections for the automation stations are incorporated on the back of the unit (see page 7).

Disposal



The printed circuit board and the housing must be disposed of separately in accordance with local regulations.

Mounting instructions

The PXM20 is suitable for control panel front mounting or vertical panels (e.g. remote operating panels or similar units). The unit is also suitable for DIN rail snap-mounting. In addition, the PXM20 can be mounted direct on any modular automation station.

Commissioning

Wiring test

When using networkable PXM20 units it is possible to carry out a wiring test of connected field devices even without a loaded application program. The field devices are shown with the current value and unit.

Switchless commissioning

The binary inputs and outputs for the commissioning phase before the programming can also be set with plant switches. They remain under control until the voltage at the devices is switched off again.

Firmware download

It is possible to download firmware via the RS232 interface.

Technical data

General device data	Operating voltage	AC 24 V ± 20 %
	Safety extra-low voltage SELV	
	Protective extra-low voltage PELV	HD 384
	Frequency	50/60 Hz
Power consumption	AC 24 V	Max. 9 VA
	DC 12 ... 40 V	Max. 4 W
Internal fuse	Thermic, automatic reset	

Operating data	Main processor	Motorola 68 SEC 000	
	Communication processor	Neuron 3150	
	Data backup in case of power failure Applications, parameter (FLASH)	> 10 years	
Keyboard	Type	Keyboard with plastic membrane and pressure point	
	Key area	7 x 7 mm	
	Switching pressure	2.1 N	
	Travel	0.6 ... 0.7 mm	
	Operating life	> 1 million operations	
	Material, front membrane	Polycarbonate	
	Material, contacts	Conductive silver, snap-on discs gold-plated	
	Display	Mechanical	
LCD display		F-STN, Black & White	
Display area		123 x 68 mm	
No. of dots		240 x 128 dots	
Dot size		0.47 x 0.47 mm	
Dot area		0.50 x 0.50 mm	
Optical			
Contrast ratio		20 : 1	
Brightness		60.0 cd/m ²	
Viewing angle		± 40°	
Viewing direction		6 o'clock	
Background lighting		CCFL (cold cathode fluorescent lamp)	
Rise time lamp		5 min = 80 % brightness	
Life time lamp		20,000 operating hours = 64 % brightness	
Interfaces		Download	RS232
		LON bus	
		Transceiver	FTT-10A
	Baud rate	78 kBit/s	
Mounting options	<ul style="list-style-type: none"> – For control panel mounting, remote operating panels, etc. – DIN rails – Direct on modular automation stations 		
Connections	See <i>page 7</i>		
Housing protection standard	Protection standard to EN 60529	IP 40 (built-in)	
Protection class	Isolation protection class	II	
Ambient conditions	Operation		
	Temperature	0 ... 50 °C	
	Humidity	< 85 % rh	
	Transport		
	Temperature	– 25 ... 65 °C	
	Humidity	< 95 % rh	
Industry standards	Product safety		
	Automatic electronic controls for household and similar use	EN 60730-1	
	Special requirements for energy controllers	EN 60730-2-11	
	Electromagnetic compatibility		
	Interference immunity	EN 50082-2	
	Emitted interference	EN 50081-1	
	Meets requirements for CE marking:		
	Electromagnetic compatibility	89/336/EEC	
	Low Voltage Directive	73/23/EEC	

Dimensions

117 x 210 x 37 mm (H x W x D)

See "Dimensions", page 7

1) Background color changes slightly depending on ambient temperature. This phenomenon is reversible.

Connections

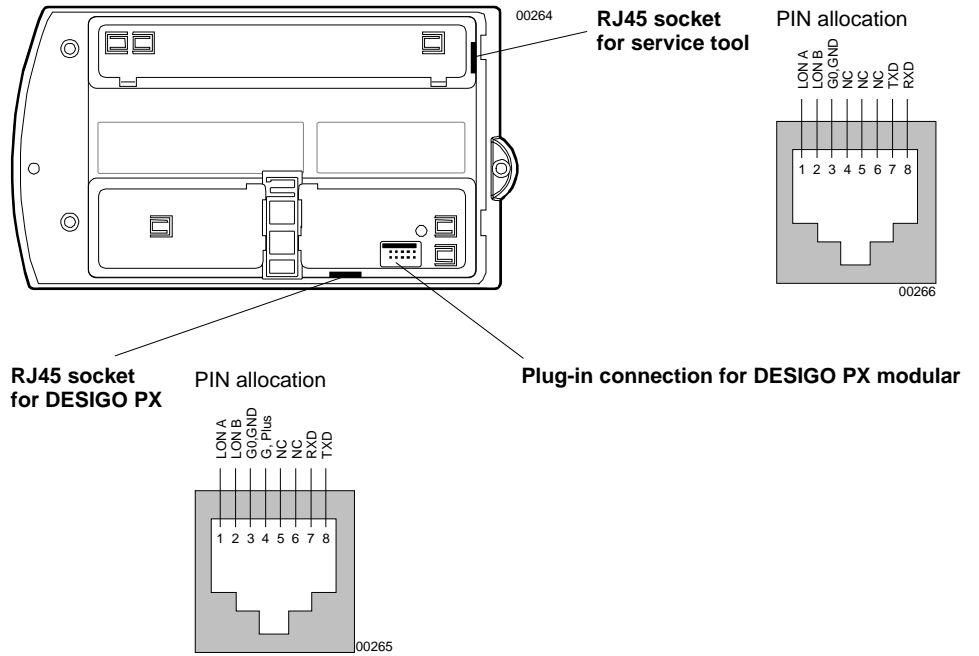

Dimensions

All dimensions in mm

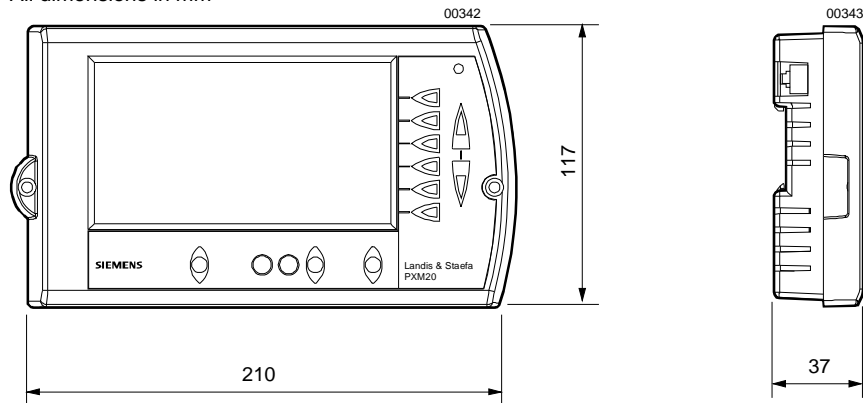

Drill and cut-out template

